

# JVC<sup>®</sup>

## OPTION HDD KIT

# SA-K51U

## INSTRUCTIONS

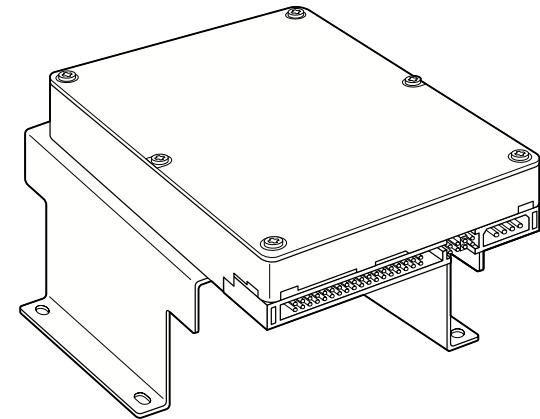

**JVC<sup>®</sup>**  
VICTOR COMPANY OF JAPAN, LIMITED

JVC<sup>®</sup> is a registered trademark owned by VICTOR COMPANY OF JAPAN, LTD.  
JVC<sup>®</sup> is a registered trademark in Japan, the U.S.A., the U.K. and many other countries.  
© 2002 VICTOR COMPANY OF JAPAN, LIMITED

 Printed in Japan  
LLT0020

**For Customer Use:**

Enter below the Serial No. which is located on the body. Retain this information for future reference.

Model No. SA-K51U

Serial No. \_\_\_\_\_

This instruction book is made from 100% recycled paper.

LLT0020

## IMPORTANT SAFEGUARDS

1. Read all of these instructions.
2. Save these instructions for later use.
3. All warnings on the product and in the operating instructions should be adhered to.
4. Unplug this appliance system from the wall outlet before cleaning. Do not use liquid cleaners or aerosol cleaners. Use a damp cloth for cleaning.
5. Do not use attachments not recommended by the appliance manufacturer as they may cause hazards.
6. Do not use this appliance near water - for example, near a bathtub, washbowl, kitchen sink, or laundry tub, in a wet basement, or near a swimming pool, etc.

PORTABLE CART WARNING  
(symbol provided by RETAC)



7. Do not place this appliance on an unstable cart, stand, or table. The appliance may fall, causing serious injury to a child or adult, and serious damage to the appliance.

Use only with a cart or stand recommended by the manufacturer, or sold with the appliance. Wall or shelf mounting should follow the manufacturer's instructions, and should use a mounting kit approved by the manufacturer. An appliance and cart combination should be moved with care.

Quick stops, excessive force, and uneven surfaces may cause the appliance and cart combination to overturn.

8. Slots and openings in the cabinet and the back or bottom are provided for ventilation, and to insure reliable operation of the appliance and to protect it from overheating, these openings must not be blocked or covered. The openings should never be blocked by placing the appliance on a bed, sofa, rug, or other similar surface.

This appliance should never be placed near or over a radiator or heat register. This appliance should not be placed in a built-in installation such as a bookcase unless proper ventilation is provided.

9. This appliance should be operated only from the type of power source indicated on the marking label. If you are not sure of the type of power supplied to your home, consult your dealer or local power company. For appliance designed to operate from battery power, refer to the operating instructions.
10. This appliance system is equipped with a 3-wire grounding type plug (a plug having a third (grounding) pin). This plug will only fit into a grounding-type power outlet. This is a safety feature. If you are unable to insert the plug into the outlet, contact your electrician to replace your obsolete outlet. Do not defeat the safety purpose of the grounding plug.

11. For added protection for this product during a lightning storm, or when it is left unattended and unused for long periods of time, unplug it from the wall outlet and disconnect the antenna or cable system. This will prevent damage to the product due to lightning and power-line surges.
12. Do not allow anything to rest on the power cord. Do not locate this appliance where the cord will be abused by persons walking on it.
13. Follow all warnings and instructions marked on the appliance.
14. Do not overload wall outlets and extension cords as this can result in fire or electric shock.
15. Never push objects of any kind into this appliance through cabinet slots as they may touch dangerous voltage points or short out parts that could result in a fire or electric shock. Never spill liquid of any kind on the appliance.
16. Do not attempt to service this appliance yourself as opening or removing covers may expose you to dangerous voltage or other hazards. Refer all servicing to qualified service personnel.
17. Unplug this appliance from the wall outlet and refer servicing to qualified service personnel under the following conditions:
  - a. When the power cord or plug is damaged or frayed.
  - b. If liquid has been spilled into the appliance.
  - c. If the appliance has been exposed to rain or water.
  - d. If the appliance does not operate normally by following the operating instructions. Adjust only those controls that are covered by the operating instructions as improper adjustment of other controls may result in damage and will often require extensive work by a qualified technician to restore the appliance to normal operation.
  - e. If the appliance has been dropped or the cabinet has been damaged.
  - f. When the appliance exhibits a distinct change in performance - this indicates a need for service.
18. When replacement parts are required, be sure the service technician has used replacement parts specified by the manufacturer that have the same characteristics as the original part. Unauthorized substitutions may result in fire, electric shock, or other hazards.
19. Upon completion of any service or repairs to this appliance, ask the service technician to perform routine safety checks to determine that the appliance is in safe operating condition.

## Safety Precautions

Thank you for purchasing this product.  
(These instructions are for SA-K51U)

Before beginning to operate this unit, please read the instruction manual carefully in order to make sure that the best possible performance is obtained.

### FOR USA AND CANADA



#### CAUTION

RISK OF ELECTRIC SHOCK  
DO NOT OPEN



CAUTION: TO REDUCE THE RISK OF ELECTRIC SHOCK, DO NOT REMOVE COVER (OR BACK). NO USER-SERVICEABLE PARTS INSIDE. REFER SERVICING TO QUALIFIED SERVICE PERSONNEL.



The lightning flash with arrowhead symbol, within an equilateral triangle is intended to alert the user to the presence of uninsulated "dangerous voltage" within the product's enclosure that may be of sufficient magnitude to constitute a risk of electric shock to persons.



The exclamation point within an equilateral triangle is intended to alert the user to the presence of important operating and maintenance (servicing) instructions in the literature accompanying the appliance.

### Information for USA

This device complies with part 15 of the FCC Rules. Changes or modifications not approved by JVC could void the user's authority to operate the equipment.

Due to design modifications, data given in this instruction book are subject to possible change without prior notice.

### WARNING:

**TO REDUCE THE RISK OF FIRE OR ELECTRIC SHOCK, DO NOT EXPOSE THIS APPLIANCE TO RAIN OR MOISTURE.**

### AVERTISSEMENT:

**POUR EVITER LES RISQUES D'INCENDIE OU D'ELECTRO-CUTION, NE PAS EXPOSER L'APPAREIL A L'HUMIDITE OU A LA PLUIE.**

### INFORMATION (FOR CANADA)

This Class B digital apparatus complies with Canadian ICES-003.

### RENSEIGNEMENT (POUR CANADA)

Cet appareil numérique de la Class B est conforme à la norme NMB-003 du Canada.

## Features

Attaching the expansion hard disk SA-K51U to the VR-510U increases the memory capacity to 160 GB and makes long-time recording possible.

## Precautions

- Ensure that the power to the VR-510U is off and the plug is removed from the power socket before attaching the SA-K51U. Not doing so may result in a fire or electric shock.
- Do not touch the edge of the metal frame, as there is the risk of injury.
- Users must not attach the SA-K51U themselves because there is the risk of a burn from an electric shock. Request your nearest JVC Service Center to perform the work. There will be a charge for the work.
- Any data recorded on the original hard disk will be lost when the SA-K51U is attached.

## How to Attach

First, set the ID of the hard disk drive to "SLAVE." Refer to the instructions on how to set the ID shown on the top (side with the model-name label affixed) of the hard disk drive.

1. Fix the SA-K51U in place by inserting the screws (silver) into the four screw holes of the stand and tightening them.

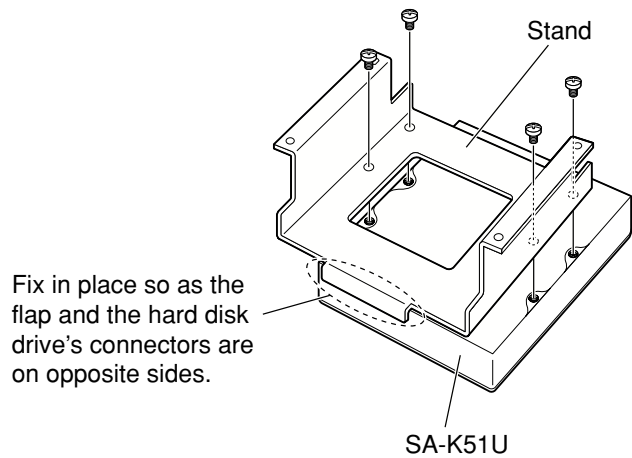

2. Open the cover of the VR-510U and remove the clamp from the power cable for the hard disk.

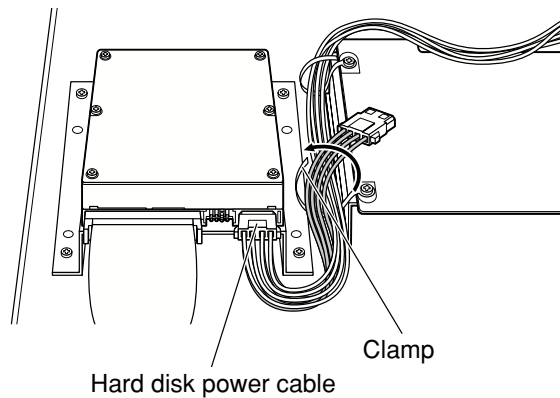

3. Fix the SA-K51U in place by inserting the screws (black) into the four screw holes of the stand and tightening them while the connector part of the SA-K51U is positioned so that it faces the rear panel of the VR-510U.

\* Keep the screws straight and steady when tightening them because the stand has non-threaded screw holes.

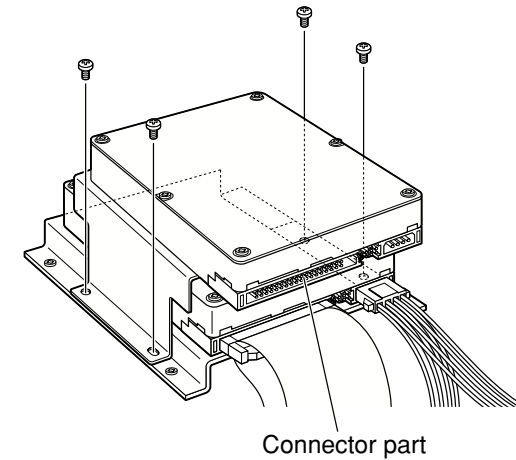

4. Connect the hard disk power cable and flat cable to the connectors on the SA-K51U.

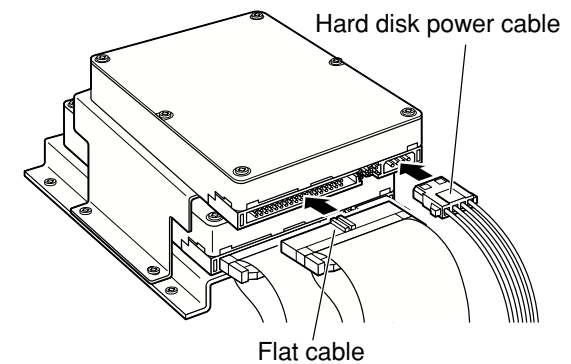

# How to Mount

The following describes how to operate the front panel of the VR-510U to mount the SA-K51U.

1. Insert the plug into the plug socket and switch on the power switch of the VR-510U.

```
3-10-02 SUN 18:03:38
AL----- %

MOUNT ERROR
```

The MOUNT ERROR message is displayed on the monitor.

\* It takes 10 to 20 seconds for the message to be displayed after the power has been switched on.

\* When the VR-510U is not receiving video input signals, INPUT SIG ERROR and MOUNT ERROR messages are displayed on the monitor alternatively.

2. Simultaneously press the MENU button and the  $\leftarrow$  button while holding down the STOP button.

```
[MENU] J.DIR |
FUNCTION-1
FUNCTION-2
HOUR METER
EMERGENCY HISTORY
OPERATION CHECK MODE
OPE VER. xx.xx
HDR VER. xx.xx
BOOT VER. xx.xx
SCSI VER. xx.xx
EXT.M VER. xx.xx
```

The MENU screen is displayed.

3. Make sure FUNCTION-1 is selected and then return the shuttle dial to the SELECT position by turning it either clockwise or anticlockwise.

```
[FUNCTION-1] J.DIR |
1.FACTORY SETTING OFF
2.HDD MOUNT [----] OFF
3.DIP SW-0 OFF
4.DIP SW-1 OFF
5.DIP SW-2 OFF
6.DIP SW-3 OFF
7.DIP SW-4 OFF
8.DIP SW-5 OFF
9.DIP SW-6 OFF
10.DIP SW-7 OFF
```

The FUNCTION-1 screen is displayed.

4. Select 2.HDD MOUNT by turning the jog dial and then return the shuttle dial to the SELECT position by turning it either clockwise or anticlockwise.

```
[FUNCTION-1] J.DIR- +
1.FACTORY SETTING OFF
2.HDD MOUNT [----] OFF
3.DIP SW-0 OFF
4.DIP SW-1 OFF
5.DIP SW-2 OFF
6.DIP SW-3 OFF
7.DIP SW-4 OFF
8.DIP SW-5 OFF
9.DIP SW-6 OFF
10.DIP SW-7 OFF
```

The jog operation switches from J.DIR  $\uparrow$   $\downarrow$  to J.DIR - +.

5. Set to standard format (STD) or extended format (EXTN) by turning the jog dial.

```
[FUNCTION-1] J.DIR- +
1.FACTORY SETTING OFF
2.HDD MOUNT [----] STD
3.DIP SW-0 OFF
4.DIP SW-1 OFF
5.DIP SW-2 OFF
6.DIP SW-3 OFF
7.DIP SW-4 OFF
8.DIP SW-5 OFF
9.DIP SW-6 OFF
10.DIP SW-7 OFF
```

Turning the jog dial switches between OFF  $\leftrightarrow$  STD  $\leftrightarrow$  EXTN  $\leftrightarrow$  OFF in order.

Selects whether the hard disk is formatted with standard or extended mode.

When the disk is formatted, all existing data on the hard disk will be erased.

STD: Normally, use this position. Up to 13,000 alarm/sensor events can be recorded.

EXTN: Set to this position if you want to be able to record more than 13,000 alarm/sensor events (up to about 100,000 events).

\* Extended formatting takes about 5 minutes to complete. Recording time is shorter than with the standard format.

6. Press the  $\rightarrow$  button to start mounting.

```
3-10-02 SUN 18:05:21
AL----- %

MOUNT xx%
INPUT SIG ERROR
```

During mounting MOUNT XX% is displayed on the monitor. Numbers are displayed instead of XX to show the progress. When mounting has finished the INPUT SIG ERROR and MOUNT ERROR messages are displayed on the monitor alternately. After approximately 10 to 20 seconds the MOUNT ERROR message disappears and mounting is complete.

## How to Verify Mounting

The following describes how to operate the front panel of the VR-510U to verify that the SA-K51U is mounted.

1. Press the MENU button.

```
[MENU] J.DIR | |
CLOCK SET
ONSCREEN / F.DISP MODE
HDR MODE
EXT MODE
ALARM / SENSOR MODE
BUZZER
PROGRAM TIMER
HOLIDAY SET
SYSTEM / LIST
```

The MENU screen is displayed.

2. Select SYSTEM/LIST by turning the jog dial and then return the shuttle dial to the SELECT position by turning it either clockwise or anticlockwise.

```
[SYSTEM] JOG | |
UTILITY [160 GB]

[LIST]
HOUR METER /
POWER LOSS LIST
```

The SYSTEM/LIST screen is displayed. Verify that 160 GB is displayed for the UTILITY item.

## Specifications

- Mass: Approx. 750 g (including stand)
- Power Consumption: 9 W or less
- Allowable operating temperature: 5°C to 40°C
- Allowable storage temperature: -20°C to 60°C
- Allowable operating humidity: 30% to 80% RH
- Accessories:
  - Stand × 1
  - Screw (silver) × 4
  - Screw (black) × 4